

Manuel utilisateur

*VL100/VL200/
VR100/VR200*

LABO-MODERNE

Copyright
LABO-MODERNE

Myr Rotational Viscometer

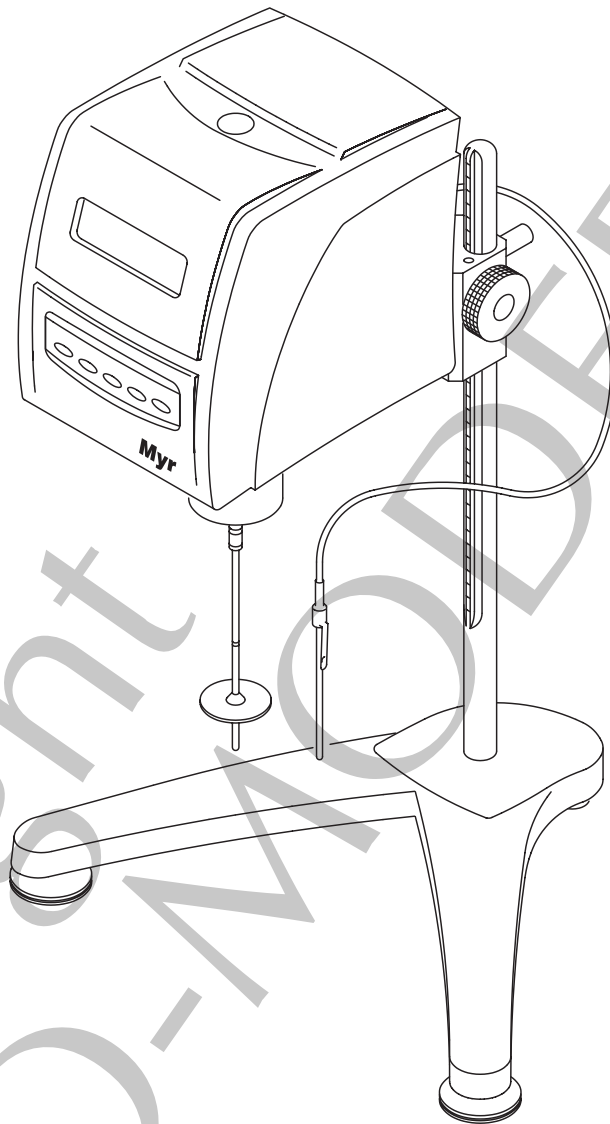

V1-L / V1-R / V1-H
V2-L / V2-R / V2-H

Copyright
LABO-MODERNE

User Manual

(Version 7.08)

COPYRIGHT
LABO-MODERNE

Contents

| | |
|--|----|
| 1. Safety | 6 |
| 2. Certification | 7 |
| 3. Warranty | 7 |
| 4. Technical specifications | 8 |
| 5. Directives and Standards applied | 9 |
| 6. Reception of the unit | 10 |
| 6.1 Supplied items | 10 |
| 6.2 Installation | 11 |
| 6.3 Connection to the mains | 11 |
| 7. Functional elements | 12 |
| 7.1 Front view | 12 |
| 7.2 Rear view | 13 |
| 8. What to order | 14 |
| 9. A few notes on viscosity | 15 |
| 9.1 Unit description | 15 |
| 9.2 Important notes | 15 |
| 9.3 Spindles | 17 |
| 10. Configuration options | 18 |
| 11. Operating | 20 |
| 11.1 Operating screen | 21 |
| 11.2 Insert the spindle | 22 |
| 11.3 Starting measurement | 22 |
| 12. Selection tables | 23 |
| 12.1 Viscometer V1 - L / V2 - L | 23 |
| 12.1.1 Standard spindles L1 – L4 | 23 |
| 12.2 Viscometer V1 - R / V2 - R | 24 |
| 12.2.1 Standard spindles R2 – R7 + optional R1 | 24 |
| 12.3 Viscometer V1 - H / V2 - H | 25 |
| 12.3.1 Standard spindles R2 – R7 + optional R1 | 25 |

Contents (cont.)

| | |
|--|----|
| 13. Accessories | 26 |
| 13.1 Adapter for small sample volumes | 26 |
| 13.1.1 Measuring range | 26 |
| 13.1.2 Description | 26 |
| 13.1.3 Assembly | 27 |
| 13.1.4 Selection tables. Special spindles | 28 |
| V1 - L / V2 - L (TL 5 - TL 7) | 28 |
| V1 - R / V2 - R (TR 8 - TR 11) | 29 |
| V1 - H / V2 - H (TR 8 - TR 11) | 30 |
| 13.2 Adapter for low viscosity materials | 31 |
| 13.2.1 Measuring range | 31 |
| 13.2.2 Description | 31 |
| 13.2.3 Assembly | 32 |
| 13.2.4 Selection table for V1 / V2 (L / R / H) | 33 |
| 13.3 Adapter for helicoidal movement | 34 |
| 13.3.1 Measuring range | 34 |
| 13.3.2 Description | 34 |
| 13.3.3 Assembly | 35 |
| 13.3.4 Selection table for V1 - L / V2 - L | 36 |
| 13.3.5 Selection table for V1 - R / V2 - R | 37 |
| 13.3.6 Selection table for V1 - H / V2 - H | 37 |
| 14. Calibration | 38 |
| 15. Troubleshooting | 38 |

1. Safety

The installation and use of the **Myr** Viscometer is simple, presenting no risk when the instructions of this manual are followed. However, those points that might present some risk for the persons or the equipment, are highlighted in this manual with the following symbols:

DANGER:



This sign indicates that if the instructions are not followed properly, injury to persons as well as material damage to the unit may occur. For your safety, observe carefully these indications.



This sign symbolizing CAUTION means that material damage may occur if these instructions are not observed. For a long service life of the unit follow instructions carefully.



This sign calls your attention to specific details of the unit whose relevance, requires special consideration.

Additionally, the following notes should be observed:

Read carefully this user manual. It contains important information for the safe handling of the device.

Ensure that this manual is always at hand for the staff operating this Viscometer.

Use this instrument only for the intended application.

Repairs or modifications of the **Myr** Viscometer should be carried out by specialized staff only. Improper repairs might cause risk to the operator and /or damage the device.

Do not clean the unit with solvents or aggressive detergents. A wet cloth soaked in hot soapy water is normally sufficient.

Do not use any accessories other than those supplied or approved by VISCOTECH HISPANIA, S.L.

Due to the fact that measurements are influenced by other factors than only the correct use and functioning of the **Myr** Viscometer, it is advisable to check results and factors involved before taking any corrective action.

2. Certification

The manufacturer certifies that this instrument has been tested and carefully verified before delivery, to be in accordance with the indicated specifications. The instrument complies with applicable safety regulations.

3. Warranty

This product is warranted for 2 years against workmanship and material defects. During this period the defective parts, when proved, will be repaired or replaced by the manufacturer free of charge. There is no other specific or implied warranty.

Non-authorized modifications or repairs by third party persons will immediately void the warranty.

The warranty does not cover improper use of the instrument, as well as, if the precaution and warning messages are not observed. The manufacturer is not responsible for any damage that might occur, except in case of real intentionality or extreme negligence of the manufacturer.

Once the guarantee has expired, it is recommended to sign a maintenance contract for the instrument. For further information on these contracts, please contact your distributor.

Despite doing our best to ensure that the features and data included in this manual are correct, the manufacturer cannot be responsible for printing errors.

This manual is subject to modifications without notice. This user manual will be supplied with each Viscometer.

4. Technical Specifications

Voltage:

100-240 V / 50-60 Hz

Power consumption:

0,2 A

Fuse:

1 x 2 AT

Speeds:

Model V1 - L/R/H: 0,3, 0,5, 0,6, 1, 1,5, 2, 2,5, 3, 4, 5, 6, 10, 12, 20, 30, 50, 60, 100, 200 rpm - 19 speeds

Model V2 - L/R/H: 0,1, 0,2, 0,3, 0,5, 0,6, 1, 1,5, 2, 2,5, 3, 4, 5, 6, 10, 12, 20, 30, 50, 60, 100, 200 rpm - 21 speeds

Viscosity range with standard spindles:

Model V1 - L: 3 – 2.000.000 mPas in 76 ranges - 19 speeds with 4 spindles.

Model V1 - R: 20 – 13.000.000 mPas in 114 ranges - 19 speeds with 6 spindles.

Model V1 - H: 1.6 – 1.066.660 dPas in 114 ranges - 19 speeds with 6 spindles.

Model V2 - L: 3 – 6.000.000 mPas in 84 ranges - 21 speeds with 4 spindles.

Model V2 - R: 20 – 40.000.000 mPas in 126 ranges - 21 speeds with 6 spindles.

Model V2 - H: 1.6 – 3.200.000 dPas in 126 ranges - 21 speeds with 6 spindles.

Accuracy: $\pm 1\%$ of full scale

Repeatability: $\pm 0.2\%$

Thermometer:

Temperature range: -15°C to $+180^{\circ}\text{C}$ (5°F to 356°F)

Resolution: $0,1^{\circ}\text{C}$ ($0,1722^{\circ}\text{F}$)

Accuracy: $\pm 0.1^{\circ}\text{C}$

Contamination:

Level 2

Surge:

Class II

Maximum altitude:

2.000m over sea level

Room temperature:

10 - 40°C

Relative humidity:

$< 80\%$

5. Directives and Standards applied

5.1 Directives

| | |
|-------------|---|
| 2006/95/CE | Related to the laws in force in the States Members regarding electrical equipment used with defined voltage limits. |
| 2004/108/CE | Related to the law in force in the States Members regarding Electromagnetic Compatibility. |

5.2 Standards

| ELECTROMAGNETIC EMISSION | |
|---|--------------------------|
| EN 61000-3-2 (2006) | Harmonics |
| EN 61000-3-3 (1995)/A1 (2001)/A2 (2005) | Voltage fluctuations |
| EN 61000-6-3 (2007) | Domestic Emission |
| EN 55022 (2006) | Continuous Conductive |
| EN 55022 (2006) | Radiated |
| ELECTROMAGNETIC IMMUNITY | |
| EN 61000-6-2 (2005) | Industrial Immunity |
| EN 61000-4-3 (2006) | Radiation Field EM of RF |
| EN 61000-4-4 (2004) | Fast transients |
| EN 61000-4-6 (2007) | RF in common mode |
| EN 61000-4-8 (1993)/A1 (2001) | Magnetic field at 50 Hz |
| EN 61000-6-1 (2007) | Domestic Immunity |
| EN 61000-4-5 (2006) | Shock wave |
| EN 61000-4-11 (2004) | Power interruption |
| EN 61000-4-2 (1995)/A1 (1998)/A2 (2001) | Electrostatic discharge |

6. Reception of the Unit

Before unpacking the **Myr** Viscometer, inspect the cardboard to check that the package has not suffered any damage during transport. If the package shows any sign of damage, do not open it and inform immediately the transport agency.

Once the instrument is unpacked, check that it has not suffered any damage. Should any be noted, inform the distributor from whom the unit was purchased.

6.1 Supplied items

- | | |
|----------------------------------|-----------------------------|
| 1. Cogged rack | 7. Spindle guard |
| 2. Viscometer | 8. Spanner tube |
| 3. Spindles L1 to L4 or R2 to R7 | 9. Case |
| 4. Stand | 10. Power supply cable |
| 5. User Manual | 11. Storage rack |
| 6. Temperature sensor | 12. Calibration certificate |

i Keep transport case delivered with instrument for possible return shipments. Parts damaged as a result of incorrect transport are not covered by the manufacturer's warranty.

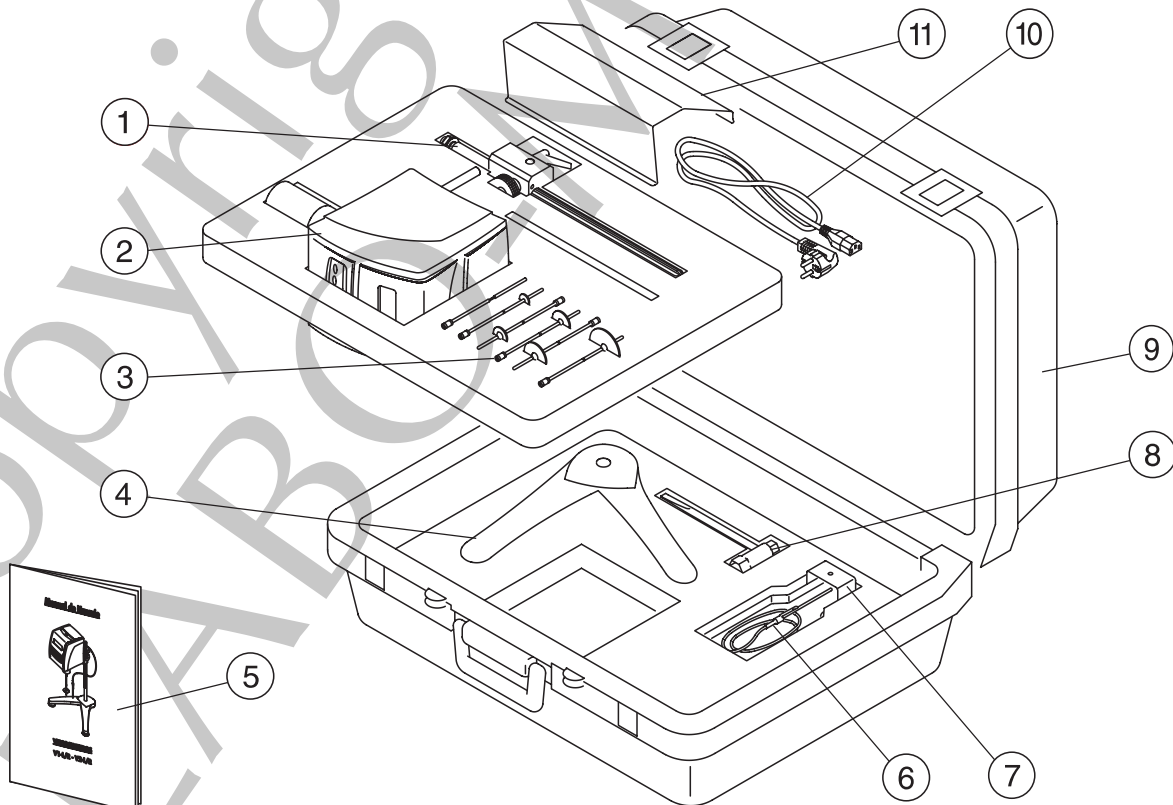

6.2 Installation

For a correct installation of the viscometer, proceed as follows :

- Remove the nut of the cogged rack .
- Locate the cogged rack in its correct position, with the slots facing the open part of the stand.
- Screw the nut of the rod through the lower insert of the stand. Tighten the nut using the supplied spanner tube.
- Insert the Viscometer's rear rod through the clamp of the cogged rack.
- Turn lever to fix the instrument.
- Place the instrument on a stable and flat surface.
- Remove the plastic protector pulling it down in vertical way. Never move the protector to the sides unless it is completely out.
- Level the instrument using the front pommels of the stand, until the level situated on the top of the instrument indicates that the instrument is leveled.
- Connect the instrument to the mains.

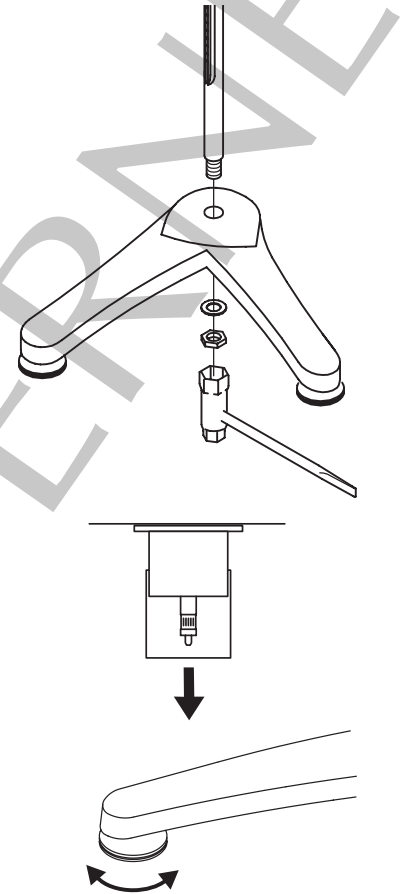

6.3 Connecting to the mains



Make sure that the mains socket is provided with a protective earth connection.

Make sure that power requirements indicated on the type plate corresponds to the power supply voltage being used.

Make sure that the plug is rated to support the maximum power consumption of the instrument.

7. Functional Elements

7.1 Front View

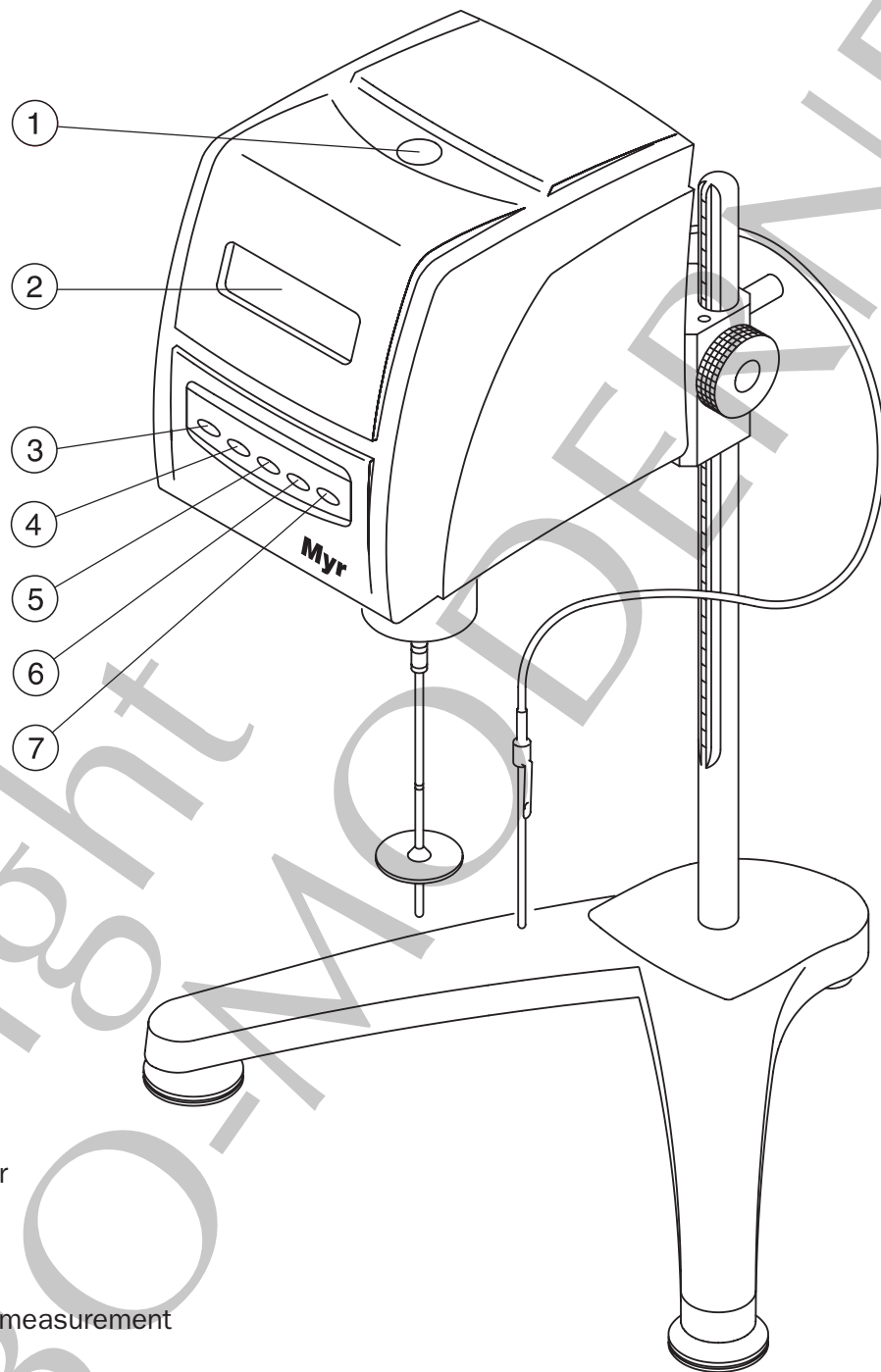

1. Levelling indicator

2. LCD Display

3.  Starts a measurement

4.  Stops a measurement

5.  Confirms parameter selection

6.  «Up» parameter selection key

7.  «Down» parameter selection key

7.2 Rear View

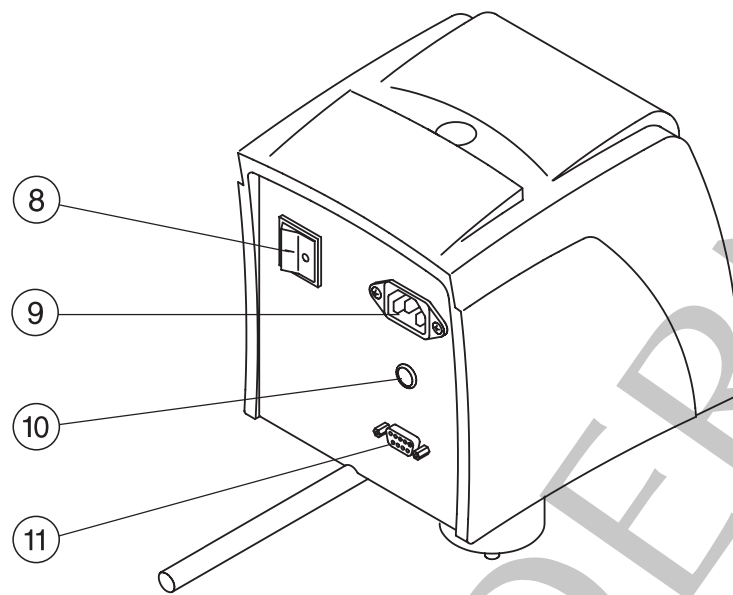

- 8. Mains switch
- 9. Power supply socket
- 10. Pt -100 connector
- 11. RS 232 connector

8. What to order

Following items are available on request:

| | |
|-----------|---|
| MY-001 | Viscometer V1-L |
| MY-002 | Viscometer V2-L |
| MY-003 | Viscometer V1-R |
| MY-004 | Viscometer V2-R |
| MY-005 | Viscometer V1-H |
| MY-006 | Viscometer V2-H |
| VTP-080 | Standard Spindle Set V1-L / V2-L (L1 - L4) |
| VTP-073 | Standard Spindle Set V1-R / V2-R / V1-H / V2-H (R2 - R7) |
| VM-007 | Special Spindle R1 |
| APM-001 | Adapter for small sample volumes |
| APM-001/T | Adapter for small sample volumes with integrated temperature sensor |
| APM-002 | Special Spindle Set V1-L / V2-L (TL5 - TL7) for adapter for small sample volumes |
| APM-003 | Special Spindle Set V1-R / V2-R / V1-H / V2-H (TR8 - TR11) for adapter for small sample volumes |
| LCP-001 | Adapter for low viscosity materials |
| LCP-001/T | Adapter for low viscosity materials with integrated temperature sensor |
| LCP-001/A | Adapter for low viscosity materials by high temperature |
| HEL-001 | Adapter for helicoidal movement |
| SFT-001 | "Viscosoft Basic" Software |
| SFT-002 | "Viscosoft Plus" Software |
| IMP-001 | Thermal Printer (complete) |

9. A few notes on viscosity

9.1 Unit description

Myr Viscometers V1 and V2 are classic rotational viscometers for the fast determination of viscosity according to following standards:

BS: 6075, 5350

ISO: 2555, 1652

ASTM: 115, 789, 1076, 1084, 1286, 1417, 1439, 1638, 1824, 2196, 2336, 2364, 2393, 2556, 2669, 2849, 2983, 2994, 3232, 3236, 3716

The principle of operation of this Viscometer is the same as all other rotational viscometers: a spindle (cylinder or disk) is submerged in the sample to be tested, measuring the force applied to overcome the resistance against rotation or flow. A spring is connected between the spindle (cylinder or disk) and the motor shaft which is rotating on a certain speed. The deviation angle of the spindle with respect to the measuring spring is measured electronically obtaining a torque value. The torque value measured with the Viscometer is based on the rotating speed and the geometry of the spindle; the result is a direct reading of the viscosity value in mPas/cP (dPas/P).

Depending on the viscosity, the resistance to the movement of a substance changes proportionally to the speed or size of the spindle. The viscometer has been calibrated to obtain viscosity readings in mPas or cP (dPas/P), considering speed and spindle type. The combination of different speeds and spindles allows optimal viscosity measurements within the wide range of the instrument.

9.2 Important Notes

Viscosity:

Viscosity is a distinctive property of the fluids. It is the measure of internal friction of a fluid when a layer of this fluid is forced to move in relation to another layer. Viscosity is a value highly dependant on temperature.

The standard units for dynamic viscosity measurements are mPa.s (S.I) or cP (C.G.S).

1mPas=1cP (centi-Poise)

1dPas=1P (Poise)

Shear Stress:

It is the force per unit/area required to produce movement in one layer of fluid in relation to another layer (internal friction). Standard units for shear stress values are N/m² (S.I) or dynes/cm² (C.G.S).

Shear rate:

It is the measure of the speed at which layers of fluid move with respect to one another. Standard unit for shear rate values is the “reciprocal second” written as sec^{-1} or $1/\text{sec}$.

Laminar flow:

It is the ideal movement between layers without transfer of mass from one to the other. It is the base to calculate dynamic viscosity.

Turbulent flow:

There is a certain speed from which a transfer of mass between layers occurs. Result is an apparently greater shear stress and an erroneously high viscosity reading. Turbulent flow is characterized by a sudden and notorious increase in viscosity above a certain speed.

Fluids can, generally speaking, be classified considering relation between shear stress and shear rate.

Newtonian fluids:

In Newtonian fluids shear stress and shear rate are in direct proportion.

Viscosity in Newtonian fluids at a given temperature, remain constant regardless of viscometer model, spindle and speed being used. The most common Newtonian fluids are water and thin motor oils.

Non –Newtonian fluids:

This kind of fluids do not show a lineal relation between shear stress and shear rate. Different working conditions have as a result different viscosity values.

Apparent viscosity is defined as the result of a fluid analysis. This result can be reproduced in another viscometer only if analysis is carried out maintaining identical working conditions and following a defined working process. Variables below influence results:

- Viscometer model.
- Dimensions of sample container.
- Filling level.
- Sample temperature.
- Spindle.
- Rotating speed.
- Spindle protector, Yes or Not.
- Duration of test (time dependant fluids).

Generally speaking each modification in the working method and working process will indefectibly lead to variations in final analysis results.

There are different behaviors within the non-newtonian fluids:

Pseudoplastic:

Samples whose viscosity decreases when increasing shear rate. It is also called “shearthinning” flow behavior. Most common pseudoplastic fluids are coatings, milk, ink and jam.

Plastic:

Under static conditions they might have a similar behaviour to a solid. For a correct evaluation of the fluid it is necessary to reach the “yield value” to make fluid flow so that product later shows any of the possible material characterizations: newtonian, pseudoplastic or dilatant.

Examples: toothpaste, chocolate, grease,

Dilatant:

Viscosity of dilatant fluids increases when shear rate increases. It is also called “shearthickening” flow behaviour

Examples: solutions of sugar and water and mixtures of sand and water.

Time depending fluids:

Apparent viscosity depends not only on shear rate but also on the time elapsed under conditions of shear.

Thixotropic:

Those fluids in which viscosity and shear stress decrease, maintaining a constant shear rate, with time.

Ketchup, honey, anti-drop paints, mayonnaise

Rheopectic:

Those fluids in which viscosity and shear stress increase, maintaining a constant shear rate, with time.

Lubricants and some paints types are rheopectic fluids.

9.3 Spindles



These accessories are made with the maximum accuracy to ensure reliable measurements according to the instrument’s specifications, as long as, the instrument is kept in good operating conditions.

10. Configuration options.



Switch on the Viscometer by pressing the mains switch. The following message will be displayed during 2 seconds (presentation screen):

V2-L V1.0
SPANISH

V1-R V1.0
SPANISH

Within the period of 2 seconds, press one after the other  and  keys. The display will show the following:

Select Language
SPANISH

Using the  or  keys, select the desired language (German, Japanese, Spanish, Polish, French, English, Italian or Portuguese). Once language is selected, press  to confirm selection.



The next screen will appear:

Viscosity Units
SI (mPas)

Using the  or  keys, select the viscosity units, SI (mPas) or CGS (cP), and confirm by pressing .



The next screen will appear:

Shear Stress Units
SI (N/m²)

Use the  or  keys to select the shear stress (S.S.) units, SI (N/m²) or CGS (Dina/cm²), and confirm by pressing . This option is only possible in model V2.



The next screen will appear:

Temperature Units
Celsius

Using the  or  keys, select the temperature units, Celsius or Fahrenheit, and confirm by pressing .

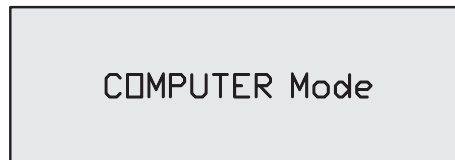
The next screen will appear:



By using  and  keys you can select PRINTER Mode or COMPUTER Mode. Press  to confirm and to skip into the next option.

PRINTER Mode selection allows the user to connect the Viscometer to a small Thermal Printer (paper roll of about 57 mm) to obtain printed viscosity measurements only when required by pressing  key.





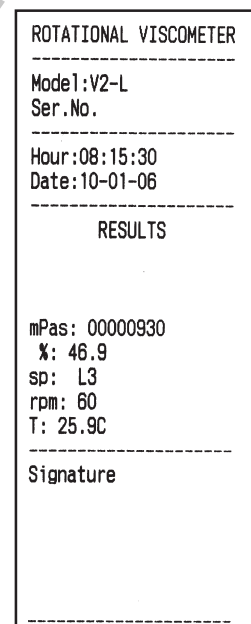

Each time user presses  key, a complete ticket as shown will be printed.

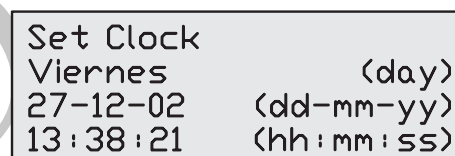
By COMPUTER Mode selection, viscometer will send the order to print continuously; therefore it should be connected to a PC. Information format in PRINTER Mode is not appropriate for small printers.



The next screen will appear:



The day of the week flashes. Use the  or  keys to change it, if necessary, and confirm the selection by pressing . The first digit of the date then begins flashing. Use the  or  keys to modify it, if necessary, and confirm by pressing . And so on successively to edit all values for the date and time.

The presentation screen will appear for 2 seconds and immediately afterwards the data screen.

11. Operating







Switch on the Viscometer by pressing the mains switch. The following message will be displayed during 2 seconds (presentation screen):

V2-L V1.0
SPANISH

V1-R V1.0
SPANISH

After 2 seconds, the data screen will show the latest used parameters (spindle and speed) stored in memory.

```
rpm 60 L4
mPas
temp 20.5°C
range 10000 mPas
```

The spindle flashes. Use the  or  keys to modify it, if necessary, and confirm the selection by pressing . The speed (rpm) then begins flashing. Use the  or  keys to modify it, if necessary, and confirm by pressing .

The parameter "range" informs about the maximum viscosity value which can be measured using the selected combination of spindle and rpm.

The message "press start" will flash on the fourth line of the display, indicating to press , turning on the motor and starting the measurement. The operating screen will appear:

```
rpm 60 L4
mPas
temp 20.5°C
Press start
```

It is possible to press the  directly on the data display. In this case, the equipment turns on the motor and starts measuring using the values of spindle and speed stored in memory.

11.1 Operating screen

Model V1

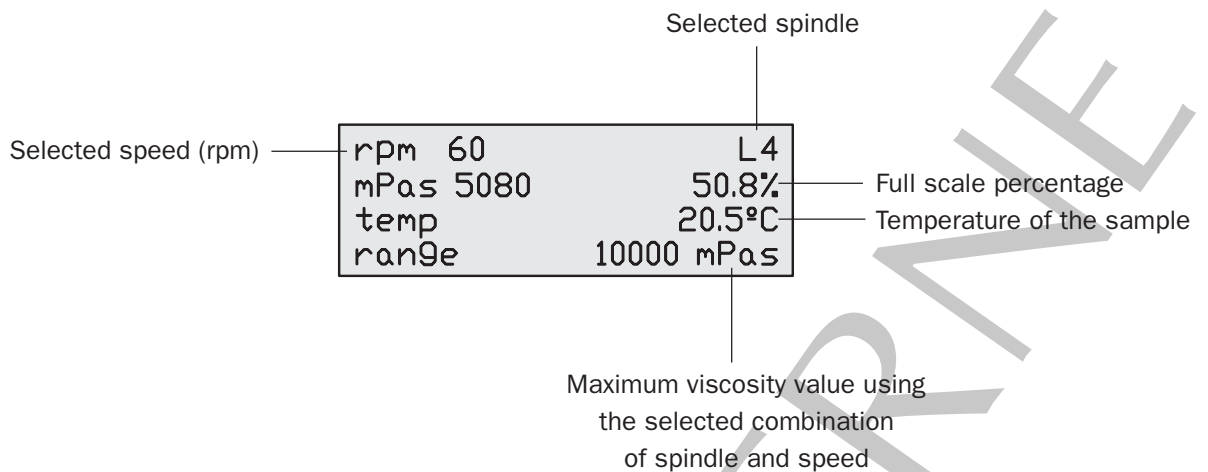

Model V2

The operating screen of model V2 is identical to model V1, unless we use some of the accessories for the absolute viscosity measurement: Adapter for Small Sample Volumes or Adapter for Low Viscosity Materials. In this case the last two lines of the display will inform about the Shear Rate (S.R.) and the Shear Stress (S.S).

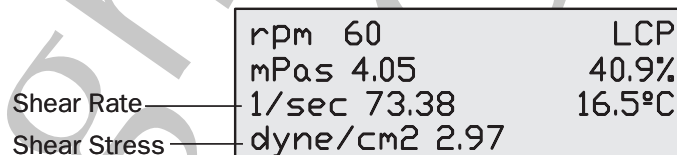

To control the operating screen, the following keys should be used:

UP or DOWN : Allows to modify the speed (rpm).

STOP : Allows to stop the motor and stop measurement.

START : Allows to switch on the motor and start a measurement.

ENTER : Press this key to quit the actual operation and return to data screen.

11.2 Inserting the spindle

If the selected spindle is of a disk type, it should be submerged carefully in sample to avoid bubbles forming under its bottom surface.

To insert the spindle, raise slightly the shaft holding it firmly with one hand and with the other hand screw the spindle.

 This operation must be done very carefully to make sure that the spindle is not bent and the shaft is not damaged

 The spindle and its counterpart with the inner thread should be clean.

Now the spindle can be immersed in the sample up to the immersion point, indicated with a groove on the same spindle. The shaft of the instrument should not be knocked against the sides of the container while the spindle is inserted since this might impair its vertical alignment.

 Spindles L4 and R7 have to be immersed up to the narrow spot. Spindles are made of AISI 316 stainless steel. Identification is engraved in each spindle.

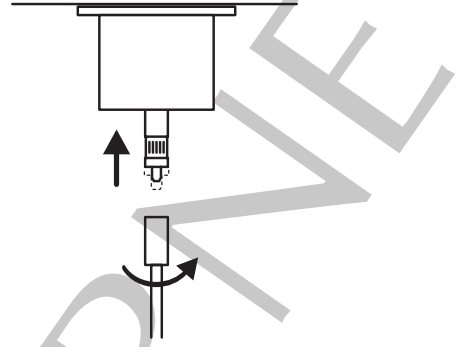

11.3 Starting the measurement

Press  to start a measurement.

Stable flow conditions are reached quickly and the reading values of the Viscometer can be considered correct within few seconds (depending on the selected speed and the viscosity of the sample) .

The message "ERROR" appearing on the screen indicates that the maximum viscosity value has been exceeded. In this case, the speed should be reduced or a larger spindle should be used.

Pressing , the instrument stops the motor, displaying the last measurement value.

The rpm's will progressively decrease until 0 rpm is reached, to protect the most delicate parts of the instrument.

On pressing  again, the viscometer will recover the preset speed value.

To modify the spindle and rpm parameters, press  to return to the data screen.

If viscosity value reading exceeds the optimum measuring range (<10% and >90% of selected full scale), the instrument will give a warning beep.

12. Selection tables

- i** The tables contain maximum orientative viscosity values.
 The minimum recommended reading is 15% of the full scale.

12.1 Viscometer V1 - L / V2 - L

Model V1 - L has 19 speeds (0,3; 0,5; 0,6; 1; 1,5; 2; 2,5; 3; 4; 5; 6; 10; 12; 20; 30; 50; 60; 100 y 200 rpm). Model V2 - L has 21 speeds (0,1; 0,2; 0,3; 0,5; 0,6; 1; 1,5; 2; 2,5; 3; 4; 5; 6; 10; 12; 20; 30; 50; 60; 100 y 200 rpm). Both models are delivered with the standard spindle set (L1 - L4).

The spindle L1 is used for low viscosity measurements. With this spindle the use of the spindle guard is indispensable to obtain correct viscosity readings.

For low viscosity samples, it is recommended to use the "Adapter for Low Viscosity Materials" and the special cylindrical spindle (LCP) to obtain higher accuracy.

The special spindle set (TL5 - TL7) is used together with the "Adapter for Small Sample Volume". It has to be ordered separately.

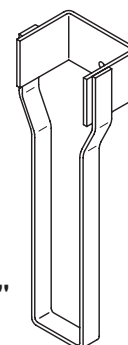

Spindle guard "L"

12.1.1 V1-L / V2-L: Standard Spindles L1 - L4

| Spindle | L1 | L2 | L3 | L4 |
|---------------|-------------------|------------------|------------------|------------------|
| rpm | Viscosity in mPas | | | |
| 0,1 (V2 only) | $6 \cdot 10^4$ | $3 \cdot 10^5$ | $1,2 \cdot 10^6$ | $6 \cdot 10^6$ |
| 0,2 (V2 only) | $3 \cdot 10^4$ | $1,5 \cdot 10^5$ | $6 \cdot 10^5$ | $3 \cdot 10^6$ |
| 0,3 | $2 \cdot 10^4$ | $1 \cdot 10^5$ | $4 \cdot 10^5$ | $2 \cdot 10^6$ |
| 0,5 | $1,2 \cdot 10^4$ | $6 \cdot 10^4$ | $2,4 \cdot 10^5$ | $1,2 \cdot 10^6$ |
| 0,6 | $1 \cdot 10^4$ | $5 \cdot 10^4$ | $2 \cdot 10^5$ | $1 \cdot 10^6$ |
| 1 | $6 \cdot 10^3$ | $3 \cdot 10^4$ | $1,2 \cdot 10^5$ | $6 \cdot 10^5$ |
| 1,5 | $4 \cdot 10^3$ | $2 \cdot 10^4$ | $8 \cdot 10^4$ | $4 \cdot 10^5$ |
| 2 | $3 \cdot 10^3$ | $1,5 \cdot 10^4$ | $6 \cdot 10^4$ | $3 \cdot 10^5$ |
| 2,5 | $2,4 \cdot 10^3$ | $1,2 \cdot 10^4$ | $4,8 \cdot 10^4$ | $2,4 \cdot 10^5$ |
| 3 | $2 \cdot 10^3$ | $1 \cdot 10^4$ | $4 \cdot 10^4$ | $2 \cdot 10^5$ |
| 4 | $1,5 \cdot 10^3$ | $7,5 \cdot 10^3$ | $3 \cdot 10^4$ | $1,5 \cdot 10^5$ |
| 5 | $1,2 \cdot 10^3$ | $6 \cdot 10^3$ | $2,4 \cdot 10^4$ | $1,2 \cdot 10^5$ |
| 6 | $1 \cdot 10^3$ | $5 \cdot 10^3$ | $2 \cdot 10^4$ | $1 \cdot 10^5$ |
| 10 | $6 \cdot 10^2$ | $3 \cdot 10^3$ | $1,2 \cdot 10^4$ | $6 \cdot 10^4$ |
| 12 | $5 \cdot 10^2$ | $2,5 \cdot 10^3$ | $1 \cdot 10^4$ | $5 \cdot 10^4$ |
| 20 | $3 \cdot 10^2$ | $1,5 \cdot 10^3$ | $6 \cdot 10^3$ | $3 \cdot 10^4$ |
| 30 | $2 \cdot 10^2$ | $1 \cdot 10^3$ | $4 \cdot 10^3$ | $2 \cdot 10^4$ |
| 50 | $1,2 \cdot 10^2$ | $6 \cdot 10^2$ | $2,4 \cdot 10^3$ | $1,2 \cdot 10^4$ |
| 60 | $1 \cdot 10^2$ | $5 \cdot 10^2$ | $2 \cdot 10^3$ | $1 \cdot 10^4$ |
| 100 | 60 | $3 \cdot 10^2$ | $1,2 \cdot 10^3$ | $6 \cdot 10^3$ |
| 200 | 30 | $1,5 \cdot 10^2$ | $6 \cdot 10^2$ | $3 \cdot 10^3$ |
| Increment | 1 mPas | 1 mPas | 10 mPas | 10 mPas |

12.2 Viscometer V1 - R / V2 - R

Model V1 - R has 19 speeds (0,3; 0,5; 0,6; 1; 1,5; 2; 2,5; 3; 4; 5; 6; 10; 12; 20; 30; 50; 60; 100 y 200 rpm). Model V2 - R has 21 speeds (0,1; 0,2; 0,3; 0,5; 0,6; 1; 1,5; 2; 2,5; 3; 4; 5; 6; 10; 12; 20; 30; 50; 60; 100 y 200 rpm). Both models are delivered with the standard spindle set (R2 – R7).

The spindle R1 is used for low viscosity measurements. With this spindle the use of the spindle guard is indispensable to obtain correct viscosity readings. Because models R are normally used for medium viscosity ranges, the spindle R1 is not very frequently used, therefore is not a standard accessory. However, it is available on request.

The special spindle set (TR8 – TR11) is used with the Adapter for Small Sample Volumes. It has to be ordered separately.

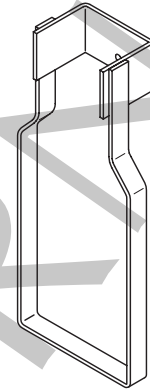

Spindle guard "R" and "H"

12.2.1 V1-R / V2-R: Standard Spindles R2 – R7 + optional R1

| Spindle | R1 option | R2 | R3 | R4 | R5 | R6 | R7 |
|---------------|-------------------|--------------------|--------------------|--------------------|--------------------|--------------------|--------------------|
| rpm | Viscosity in mPas | | | | | | |
| 0,1 (V2 only) | $1 \cdot 10^5$ | $4 \cdot 10^5$ | $1 \cdot 10^6$ | $2 \cdot 10^6$ | $3,9 \cdot 10^6$ | $1 \cdot 10^7$ | $4 \cdot 10^7$ |
| 0,2 (V2 only) | $5 \cdot 10^4$ | $2 \cdot 10^5$ | $5 \cdot 10^5$ | $1 \cdot 10^6$ | $2 \cdot 10^6$ | $5 \cdot 10^6$ | $2 \cdot 10^7$ |
| 0,3 | $33,3 \cdot 10^3$ | $133,3 \cdot 10^3$ | $333,3 \cdot 10^3$ | $666,6 \cdot 10^3$ | $1,3 \cdot 10^6$ | $3,33 \cdot 10^6$ | $13,3 \cdot 10^6$ |
| 0,5 | $2 \cdot 10^4$ | $8 \cdot 10^4$ | $2 \cdot 10^5$ | $4 \cdot 10^5$ | $8 \cdot 10^5$ | $2 \cdot 10^6$ | $8 \cdot 10^6$ |
| 0,6 | $16,6 \cdot 10^3$ | $66,6 \cdot 10^3$ | $166,6 \cdot 10^3$ | $333,3 \cdot 10^3$ | $666,6 \cdot 10^3$ | $1,6 \cdot 10^6$ | $6,6 \cdot 10^6$ |
| 1 | $1 \cdot 10^4$ | $4 \cdot 10^4$ | $1 \cdot 10^5$ | $2 \cdot 10^5$ | $4 \cdot 10^5$ | $1 \cdot 10^6$ | $4 \cdot 10^6$ |
| 1,5 | $6,6 \cdot 10^3$ | $26,6 \cdot 10^3$ | $66,6 \cdot 10^3$ | $133,3 \cdot 10^3$ | $266,6 \cdot 10^3$ | $666,6 \cdot 10^3$ | $2,6 \cdot 10^6$ |
| 2 | $5 \cdot 10^3$ | $2 \cdot 10^4$ | $5 \cdot 10^4$ | $1 \cdot 10^5$ | $2 \cdot 10^5$ | $5 \cdot 10^5$ | $2 \cdot 10^6$ |
| 2,5 | $4 \cdot 10^3$ | $16 \cdot 10^3$ | $4 \cdot 10^4$ | $8 \cdot 10^4$ | $16 \cdot 10^4$ | $4 \cdot 10^5$ | $1,6 \cdot 10^6$ |
| 3 | $3,3 \cdot 10^3$ | $13,3 \cdot 10^3$ | $33,3 \cdot 10^3$ | $66,6 \cdot 10^3$ | $133,3 \cdot 10^3$ | $333,3 \cdot 10^3$ | $1,3 \cdot 10^6$ |
| 4 | $2,5 \cdot 10^3$ | $1 \cdot 10^4$ | $2,5 \cdot 10^4$ | $5 \cdot 10^4$ | $1 \cdot 10^5$ | $25 \cdot 10^4$ | $1 \cdot 10^6$ |
| 5 | $2 \cdot 10^3$ | $8 \cdot 10^3$ | $2 \cdot 10^4$ | $4 \cdot 10^4$ | $8 \cdot 10^4$ | $2 \cdot 10^5$ | $8 \cdot 10^5$ |
| 6 | $1,6 \cdot 10^3$ | $6,6 \cdot 10^3$ | $16,6 \cdot 10^3$ | $33,3 \cdot 10^3$ | $66,6 \cdot 10^3$ | $166,6 \cdot 10^3$ | $66,6 \cdot 10^3$ |
| 10 | $1 \cdot 10^3$ | $4 \cdot 10^3$ | $1 \cdot 10^4$ | $2 \cdot 10^4$ | $4 \cdot 10^4$ | $1 \cdot 10^5$ | $4 \cdot 10^5$ |
| 12 | $8,33 \cdot 10^2$ | $3,3 \cdot 10^3$ | $8,3 \cdot 10^3$ | $16,6 \cdot 10^3$ | $33,3 \cdot 10^3$ | $83,3 \cdot 10^3$ | $333,3 \cdot 10^3$ |
| 20 | $5 \cdot 10^2$ | $2 \cdot 10^3$ | $5 \cdot 10^3$ | $1 \cdot 10^4$ | $2 \cdot 10^4$ | $5 \cdot 10^4$ | $2 \cdot 10^5$ |
| 30 | $3,33 \cdot 10^2$ | $1,3 \cdot 10^3$ | $3,3 \cdot 10^3$ | $6,6 \cdot 10^3$ | $13,3 \cdot 10^3$ | $33,3 \cdot 10^3$ | $133,3 \cdot 10^3$ |
| 50 | $2 \cdot 10^2$ | $8 \cdot 10^2$ | $2 \cdot 10^3$ | $4 \cdot 10^3$ | $8 \cdot 10^3$ | $2 \cdot 10^4$ | $8 \cdot 10^4$ |
| 60 | $1,66 \cdot 10^2$ | $6,6 \cdot 10^2$ | $1,6 \cdot 10^3$ | $3,3 \cdot 10^3$ | $6,6 \cdot 10^3$ | $16,6 \cdot 10^3$ | $66,6 \cdot 10^3$ |
| 100 | $1 \cdot 10^2$ | $4 \cdot 10^2$ | $1 \cdot 10^3$ | $2 \cdot 10^3$ | $4 \cdot 10^3$ | $1 \cdot 10^4$ | $4 \cdot 10^4$ |
| 200 | 50 | $2 \cdot 10^2$ | $5 \cdot 10^2$ | $1 \cdot 10^3$ | $2 \cdot 10^3$ | $5 \cdot 10^3$ | $2 \cdot 10^4$ |
| Increment | 1 mPas | 1 mPas | 10 mPas | 10 mPas | 10 mPas | 100 mPas | 100 mPas |

12.3 Viscometer V1 - H / V2 - H

Model V1 - H has 19 speeds (0,3; 0,5; 0,6; 1; 1,5; 2; 2,5; 3; 4; 5; 6; 10; 12; 20; 30; 50; 60; 100 y 200 rpm). Model V2 - H has 21 speeds (0,1; 0,2; 0,3; 0,5; 0,6; 1; 1,5; 2; 2,5; 3; 4; 5; 6; 10; 12; 20; 30; 50; 60; 100 y 200 rpm). Both models are delivered with the standard spindle set (R2 – R7).

The spindle R1 is used for low viscosity measurements. With this spindle the use of the spindle guard is indispensable to obtain correct viscosity readings. Because models H are normally used for high viscosity ranges, the spindle R1 is not very frequently used, therefore is not a standard accessory. However, it is available on request.

The special spindle set (TR8 – TR11) is used with the Adapter for Small Sample Volumes. It has to be ordered separately.

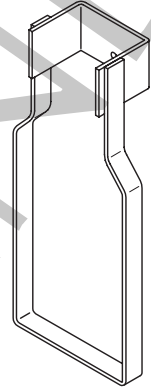

Spindle guard "R" and "H"

12.3.1 V1-H / V2-H: Standard Spindles R2 – R7 + optional R1

| Spindle | R1 option | R2 | R3 | R4 | R5 | R6 | R7 |
|---------------|-------------------|-------------------|-------------------|-------------------|-------------------|-------------------|-------------------|
| rpm | Viscosity in dPas | | | | | | |
| 0,1 (V2 only) | $8,0 \cdot 10^3$ | $3,2 \cdot 10^4$ | $8,0 \cdot 10^4$ | $1,6 \cdot 10^5$ | $3,2 \cdot 10^5$ | $8,0 \cdot 10^5$ | $3,2 \cdot 10^6$ |
| 0,2 (V2 only) | $4,0 \cdot 10^3$ | $1,6 \cdot 10^4$ | $4,0 \cdot 10^4$ | $8,0 \cdot 10^4$ | $1,6 \cdot 10^5$ | $4,0 \cdot 10^5$ | $1,6 \cdot 10^6$ |
| 0,3 | $2,66 \cdot 10^3$ | $1,06 \cdot 10^4$ | $2,66 \cdot 10^4$ | $5,33 \cdot 10^4$ | $1,06 \cdot 10^5$ | $2,66 \cdot 10^5$ | $1,06 \cdot 10^6$ |
| 0,5 | $1,6 \cdot 10^3$ | $6,4 \cdot 10^3$ | $1,6 \cdot 10^4$ | $3,2 \cdot 10^4$ | $6,4 \cdot 10^4$ | $1,6 \cdot 10^5$ | $6,4 \cdot 10^5$ |
| 0,6 | $1,33 \cdot 10^3$ | $5,33 \cdot 10^3$ | $1,33 \cdot 10^4$ | $2,66 \cdot 10^4$ | $5,3 \cdot 10^4$ | $1,33 \cdot 10^5$ | $5,33 \cdot 10^5$ |
| 1 | $8,0 \cdot 10^2$ | $3,2 \cdot 10^3$ | $8,0 \cdot 10^3$ | $1,6 \cdot 10^4$ | $3,2 \cdot 10^4$ | $8,0 \cdot 10^4$ | $3,2 \cdot 10^5$ |
| 1,5 | $5,33 \cdot 10^2$ | $2,13 \cdot 10^3$ | $5,33 \cdot 10^3$ | $1,06 \cdot 10^4$ | $2,13 \cdot 10^4$ | $5,33 \cdot 10^4$ | $2,13 \cdot 10^5$ |
| 2 | $4,0 \cdot 10^2$ | $1,6 \cdot 10^3$ | $4,0 \cdot 10^3$ | $8,0 \cdot 10^3$ | $1,6 \cdot 10^4$ | $4,0 \cdot 10^4$ | $1,6 \cdot 10^5$ |
| 2,5 | $3,2 \cdot 10^2$ | $1,28 \cdot 10^3$ | $3,2 \cdot 10^3$ | $6,4 \cdot 10^3$ | $1,28 \cdot 10^4$ | $3,2 \cdot 10^4$ | $1,28 \cdot 10^5$ |
| 3 | $2,66 \cdot 10^2$ | $1,06 \cdot 10^3$ | $2,66 \cdot 10^3$ | $5,3 \cdot 10^3$ | $1,06 \cdot 10^4$ | $2,66 \cdot 10^4$ | $1,06 \cdot 10^5$ |
| 4 | $2,0 \cdot 10^2$ | $8,0 \cdot 10^2$ | $2,0 \cdot 10^3$ | $4,0 \cdot 10^3$ | $8,0 \cdot 10^3$ | $2,0 \cdot 10^4$ | $8,0 \cdot 10^4$ |
| 5 | $1,6 \cdot 10^2$ | $6,4 \cdot 10^2$ | $1,6 \cdot 10^3$ | $3,2 \cdot 10^3$ | $6,4 \cdot 10^3$ | $1,66 \cdot 10^4$ | $6,4 \cdot 10^4$ |
| 6 | $1,3 \cdot 10^2$ | $5,3 \cdot 10^2$ | $1,33 \cdot 10^3$ | $2,66 \cdot 10^3$ | $5,33 \cdot 10^3$ | $1,33 \cdot 10^4$ | $5,33 \cdot 10^4$ |
| 10 | 80,0 | $3,2 \cdot 10^2$ | $8,0 \cdot 10^2$ | $1,6 \cdot 10^3$ | $3,2 \cdot 10^3$ | $8,0 \cdot 10^3$ | $3,2 \cdot 10^4$ |
| 12 | 66,6 | $2,66 \cdot 10^2$ | $6,6 \cdot 10^2$ | $1,33 \cdot 10^3$ | $2,66 \cdot 10^3$ | $6,66 \cdot 10^3$ | $2,66 \cdot 10^4$ |
| 20 | 40,0 | $1,6 \cdot 10^2$ | $4,0 \cdot 10^2$ | $8,0 \cdot 10^2$ | $1,6 \cdot 10^3$ | $4,0 \cdot 10^3$ | $1,6 \cdot 10^4$ |
| 30 | 26,6 | $1,06 \cdot 10^2$ | $2,66 \cdot 10^2$ | $5,33 \cdot 10^2$ | $1,06 \cdot 10^3$ | $2,66 \cdot 10^3$ | $1,06 \cdot 10^4$ |
| 50 | 16,0 | 64,0 | $1,6 \cdot 10^2$ | $3,2 \cdot 10^2$ | $6,4 \cdot 10^2$ | $1,6 \cdot 10^3$ | $6,4 \cdot 10^3$ |
| 60 | 13,3 | 53,0 | $1,33 \cdot 10^2$ | $2,6 \cdot 10^2$ | $5,3 \cdot 10^2$ | $1,33 \cdot 10^3$ | $5,33 \cdot 10^3$ |
| 100 | 8,0 | 32,0 | 80,0 | $1,6 \cdot 10^2$ | $3,2 \cdot 10^2$ | $8,0 \cdot 10^2$ | $3,2 \cdot 10^3$ |
| 200 | 4,0 | 16,0 | 40,0 | 80,0 | $1,6 \cdot 10^2$ | $4,0 \cdot 10^2$ | $1,6 \cdot 10^3$ |

13. Accessories

13.1 Adapter for small sample volumes

13.1.1 Measuring range

| | |
|-------------------|--------------------------|
| MODEL V1L: | 1,5* - 200.000 mPas/cP |
| MODEL V1R: | 25* - 3.300.000 mPas/cP |
| MODEL V1H: | 2* - 266.000 dPas/P |
| MODEL V2L: | 1,5* - 600.00 mPas/cP |
| MODEL V2R: | 25* - 10.000.000 mPas/cP |
| MODEL V2H: | 2* - 800.000 dPas/P |

- * High rotational speeds required for very low viscosity measurements might have a negative influence on viscosity readings.
- * Viscosity measurements have to be done under laminar flow conditions and not under turbulent ones. Turbulence creates a falsely high viscosity reading.

13.1.2 Description

The Adapter for small sample volume is an accessory which consists in a precision spindle rotating inside a sample container. Container fits into a circulating water jacket for precise temperature control (between -10°C/100°C).

It needs to be ordered separately together with the set of special cylindrical spindles suitable for the viscometer version being used.

It is commonly used when sample available is in very small quantities (8 – 13 ml)

This accessory offers 2 versions:

(APM-001): Standard Adapter

(APM-001/T): Adapter with embedded temperature sensor in lower cap for a direct readout of sample temperature.

13.1.3 Assembly:

- Fix the circulating water jacket ① to the rear support ② through the screw ③.
- Close the sample container ④ with the lower cap ⑤. Make sure it is properly tightened up.
- Fill up the sample container ④. Take care that no air bubbles remain in the bottom of the container. To fill it up, use a large syringe while inclining the container. Quantity of sample required is very small (8 to 13 ml)
- Check sample quantity. A correct sample level should cover the spindle completely.
- Hang spindle required ⑥ onto the spindle hook ⑦. Attach spindle hook to the screw ⑧.
- Introduce spindle with hook and screw into sample container.
- Insert the sample container ④ into the circulating water jacket ① from below.
- Lock the sample container ④ to the circulating water jacket ①. Groove in lower cap ⑤ has to meet fixing screw in circulating water jacket ⑨. Turn sample container to fix it.
- Add on the upper cap ⑩. Take care that spindle does not slip into sample container. Let spindle lean on upper cap.
- Fix the rear support ② to the viscometer through screw ⑪.

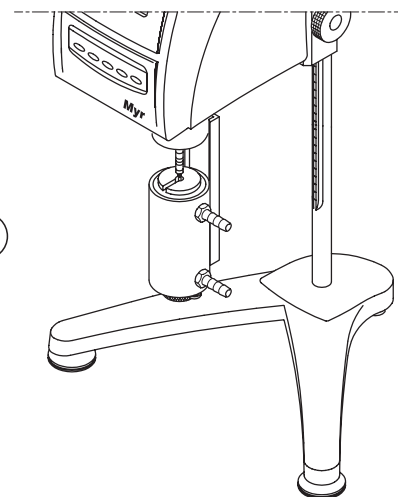
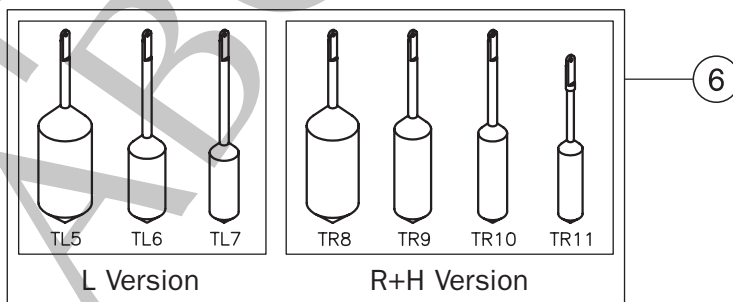
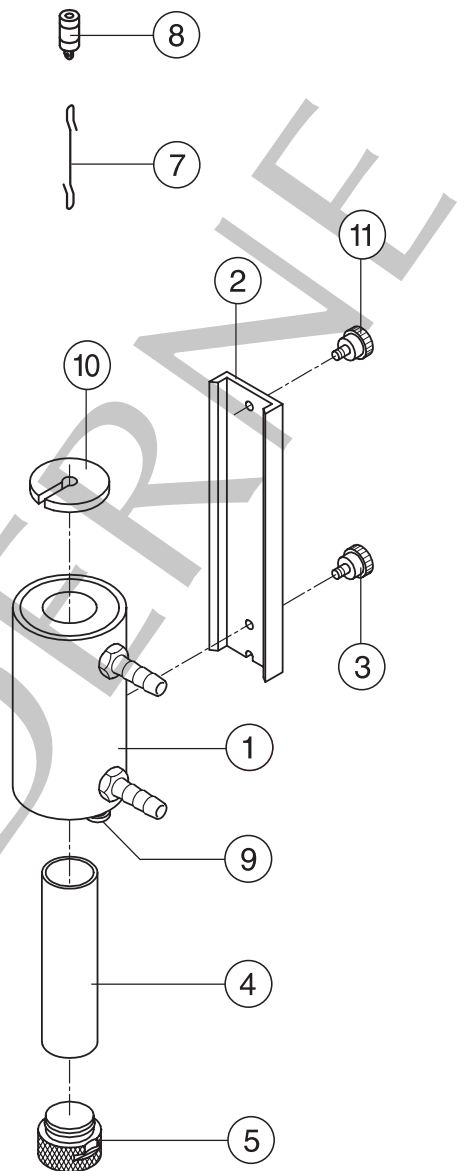

13.1.4 Selection tables Special spindles

V1-L / V2-L (TL5 - TL7)

| Spindle | TL5 | TL6 | TL7 |
|---------------|-------------------|------------------|------------------|
| rpm | Viscosity in mPas | | |
| 0,1 (V2 only) | $3 \cdot 10^4$ | $3 \cdot 10^5$ | $6 \cdot 10^5$ |
| 0,2 (V2 only) | $1,5 \cdot 10^4$ | $1,5 \cdot 10^5$ | $3 \cdot 10^5$ |
| 0,3 | $1 \cdot 10^4$ | $1 \cdot 10^5$ | $2 \cdot 10^5$ |
| 0,5 | $6 \cdot 10^3$ | $6 \cdot 10^4$ | $1,2 \cdot 10^5$ |
| 0,6 | $5 \cdot 10^3$ | $5 \cdot 10^4$ | $1 \cdot 10^5$ |
| 1 | $3 \cdot 10^3$ | $3 \cdot 10^4$ | $6 \cdot 10^4$ |
| 1,5 | $2 \cdot 10^3$ | $2 \cdot 10^4$ | $4 \cdot 10^4$ |
| 2 | $1,5 \cdot 10^3$ | $1,5 \cdot 10^4$ | $3 \cdot 10^4$ |
| 2,5 | $1,2 \cdot 10^3$ | $1,2 \cdot 10^4$ | $2,4 \cdot 10^4$ |
| 3 | $1 \cdot 10^3$ | $1 \cdot 10^4$ | $2 \cdot 10^4$ |
| 4 | $7,5 \cdot 10^2$ | $7,5 \cdot 10^3$ | $1,5 \cdot 10^4$ |
| 5 | $6 \cdot 10^2$ | $6 \cdot 10^3$ | $1,2 \cdot 10^4$ |
| 6 | $5 \cdot 10^2$ | $5 \cdot 10^3$ | $1 \cdot 10^4$ |
| 10 | $3 \cdot 10^2$ | $3 \cdot 10^3$ | $6 \cdot 10^3$ |
| 12 | $2,5 \cdot 10^2$ | $2,5 \cdot 10^3$ | $5 \cdot 10^3$ |
| 20 | $1,5 \cdot 10^2$ | $1,5 \cdot 10^3$ | $3 \cdot 10^3$ |
| 30 | $1 \cdot 10^2$ | $1 \cdot 10^3$ | $2 \cdot 10^3$ |
| 50 | 60 | $6 \cdot 10^2$ | $1,2 \cdot 10^3$ |
| 60 | 50 | $5 \cdot 10^2$ | $1 \cdot 10^3$ |
| 100 | 30 | $3 \cdot 10^2$ | $6 \cdot 10^2$ |
| 200 | 15 | $1,5 \cdot 10^2$ | $3 \cdot 10^2$ |
| Increment | 0,1 mPas | 1 mPas | 10 mPas |

Special Spindles Characteristics

| Spindle | Shear Rate (S.R.) (Seg. ⁻¹) | Sample Volume (cc) |
|------------|--|-----------------------|
| TL5 | $1,32 \cdot \text{rpm}$ | 8,0 |
| TL6 | $0,34 \cdot \text{rpm}$ | 10,0 |
| TL7 | $0,28 \cdot \text{rpm}$ | 9,5 |

The Shear Rate (S.R.) has been calculated assuming the characteristics of newtonian products.

V1-R / V2-R (TR8 - TR11)

| Spindle | TR8 | TR9 | TR10 | TR11 |
|---------------|--------------------|--------------------|--------------------|--------------------|
| rpm | Viscosity in mPas | | | |
| 0,1 (V2 only) | $5 \cdot 10^5$ | $2,5 \cdot 10^6$ | $5 \cdot 10^6$ | $1 \cdot 10^7$ |
| 0,2 (V2 only) | $2,5 \cdot 10^5$ | $1,3 \cdot 10^6$ | $2,5 \cdot 10^6$ | $5 \cdot 10^6$ |
| 0,3 | $166,6 \cdot 10^3$ | $833,3 \cdot 10^3$ | $1,6 \cdot 10^6$ | $3,3 \cdot 10^6$ |
| 0,5 | $1 \cdot 10^5$ | $5 \cdot 10^5$ | $1 \cdot 10^6$ | $2 \cdot 10^6$ |
| 0,6 | $83,3 \cdot 10^3$ | $416,6 \cdot 10^3$ | $833,3 \cdot 10^3$ | $1,6 \cdot 10^6$ |
| 1 | $5 \cdot 10^4$ | $25 \cdot 10^4$ | $5 \cdot 10^5$ | $1 \cdot 10^6$ |
| 1,5 | $33,3 \cdot 10^3$ | $166,6 \cdot 10^3$ | $333,3 \cdot 10^3$ | $666,6 \cdot 10^3$ |
| 2 | $25 \cdot 10^3$ | $125 \cdot 10^3$ | $25 \cdot 10^4$ | $5 \cdot 10^5$ |
| 2,5 | $2 \cdot 10^4$ | $1 \cdot 10^5$ | $2 \cdot 10^5$ | $4 \cdot 10^5$ |
| 3 | $16,6 \cdot 10^3$ | $83,3 \cdot 10^3$ | $166,6 \cdot 10^3$ | $333,3 \cdot 10^3$ |
| 4 | $12,5 \cdot 10^3$ | $62,5 \cdot 10^3$ | $125 \cdot 10^3$ | $25 \cdot 10^4$ |
| 5 | $1 \cdot 10^4$ | $5 \cdot 10^4$ | $1 \cdot 10^5$ | $2 \cdot 10^5$ |
| 6 | $8,3 \cdot 10^3$ | $41,6 \cdot 10^3$ | $83,3 \cdot 10^3$ | $166,6 \cdot 10^3$ |
| 10 | $5 \cdot 10^3$ | $25 \cdot 10^3$ | $5 \cdot 10^4$ | $1 \cdot 10^5$ |
| 12 | $4,16 \cdot 10^3$ | $20,83 \cdot 10^3$ | $41,6 \cdot 10^3$ | $83,3 \cdot 10^3$ |
| 20 | $2,5 \cdot 10^3$ | $12,5 \cdot 10^3$ | $25 \cdot 10^3$ | $5 \cdot 10^4$ |
| 30 | $1,6 \cdot 10^3$ | $8,3 \cdot 10^3$ | $16,6 \cdot 10^3$ | $33,3 \cdot 10^3$ |
| 50 | $1 \cdot 10^3$ | $5 \cdot 10^3$ | $1 \cdot 10^4$ | $2 \cdot 10^4$ |
| 60 | $83,3 \cdot 10^2$ | $4,16 \cdot 10^3$ | $8,3 \cdot 10^3$ | $16,6 \cdot 10^3$ |
| 100 | $5 \cdot 10^2$ | $2,5 \cdot 10^3$ | $5 \cdot 10^3$ | $1 \cdot 10^4$ |
| 200 | $2,5 \cdot 10^2$ | $1,25 \cdot 10^3$ | $2,5 \cdot 10^3$ | $5 \cdot 10^3$ |
| Increment | 10 mPas | 100 mPas | 100 mPas | 100 mPas |

Special Spindles Characteristics

| Spindle | Shear Rate (S.R.) (Seg.^{-1}) | Sample Volume (cc) |
|-------------|---|-----------------------|
| TR8 | $0,93 \cdot \text{rpm}$ | 8,0 |
| TR9 | $0,34 \cdot \text{rpm}$ | 10,5 |
| TR10 | $0,28 \cdot \text{rpm}$ | 11,5 |
| TR11 | $0,25 \cdot \text{rpm}$ | 13,0 |

The Shear Rate (S.R.) has been calculated assuming the characteristics of newtonian products.

V1-H / V2-H (TR8 – TR11)

| Spindle | TR8 | TR9 | TR10 | TR11 |
|---------------|-------------------|-------------------|-------------------|-------------------|
| rpm | Viscosity in dPas | | | |
| 0.1 (V2 only) | $4,0 \cdot 10^4$ | $2,0 \cdot 10^5$ | $4,0 \cdot 10^5$ | $8,0 \cdot 10^5$ |
| 0.2 (V2 only) | $2,0 \cdot 10^4$ | $1,0 \cdot 10^5$ | $2,0 \cdot 10^5$ | $4,0 \cdot 10^5$ |
| 0.3 | $1,3 \cdot 10^4$ | $6,66 \cdot 10^4$ | $1,33 \cdot 10^5$ | $2,66 \cdot 10^5$ |
| 0.5 | $8,0 \cdot 10^3$ | $4,0 \cdot 10^4$ | $8,0 \cdot 10^4$ | $1,6 \cdot 10^5$ |
| 0.6 | $6,6 \cdot 10^3$ | $3,33 \cdot 10^4$ | $6,66 \cdot 10^4$ | $1,33 \cdot 10^5$ |
| 1 | $4,0 \cdot 10^3$ | $2,0 \cdot 10^4$ | $4,0 \cdot 10^4$ | $8,0 \cdot 10^4$ |
| 1.5 | $2,6 \cdot 10^3$ | $1,33 \cdot 10^4$ | $2,66 \cdot 10^4$ | $5,33 \cdot 10^4$ |
| 2 | $2,0 \cdot 10^3$ | $1,0 \cdot 10^4$ | $2,0 \cdot 10^4$ | $4,0 \cdot 10^4$ |
| 2.5 | $1,6 \cdot 10^3$ | $8 \cdot 10^3$ | $1,66 \cdot 10^4$ | $3,2 \cdot 10^4$ |
| 3 | $1,33 \cdot 10^3$ | $6,66 \cdot 10^3$ | $1,33 \cdot 10^4$ | $2,66 \cdot 10^4$ |
| 4 | $1,0 \cdot 10^3$ | $5,0 \cdot 10^3$ | $1,0 \cdot 10^4$ | $2,0 \cdot 10^4$ |
| 5 | $8,0 \cdot 10^2$ | $4,0 \cdot 10^3$ | $8,0 \cdot 10^3$ | $1,66 \cdot 10^4$ |
| 6 | $6,6 \cdot 10^2$ | $3,33 \cdot 10^3$ | $6,66 \cdot 10^3$ | $1,33 \cdot 10^4$ |
| 10 | $4,0 \cdot 10^2$ | $2 \cdot 10^3$ | $4,0 \cdot 10^3$ | $8,0 \cdot 10^3$ |
| 12 | $3,3 \cdot 10^2$ | $1,66 \cdot 10^3$ | $3,33 \cdot 10^3$ | $6,66 \cdot 10^3$ |
| 20 | $2,0 \cdot 10^2$ | $1 \cdot 10^3$ | $2,0 \cdot 10^3$ | $4,0 \cdot 10^3$ |
| 30 | $1,3 \cdot 10^2$ | $6,6 \cdot 10^2$ | $1,33 \cdot 10^3$ | $2,66 \cdot 10^3$ |
| 50 | 80,0 | $4 \cdot 10^2$ | $8,0 \cdot 10^2$ | $1,6 \cdot 10^3$ |
| 60 | 66,6 | $3,3 \cdot 10^2$ | $6,66 \cdot 10^2$ | $1,33 \cdot 10^3$ |
| 100 | 40,0 | $2,0 \cdot 10^2$ | $4,0 \cdot 10^2$ | $8,0 \cdot 10^2$ |
| 200 | 20,0 | $1,0 \cdot 10^2$ | $2,0 \cdot 10^2$ | $4,0 \cdot 10^2$ |

Special Spindles Characteristics

| Spindle | Shear Rate (S.R.) (Seg^{-1}) | Sample Volume (cc) |
|-------------|--|-----------------------|
| TR8 | $0,93 \cdot \text{rpm}$ | 8,0 |
| TR9 | $0,34 \cdot \text{rpm}$ | 10,5 |
| TR10 | $0,28 \cdot \text{rpm}$ | 11,5 |
| TR11 | $0,25 \cdot \text{rpm}$ | 13,0 |

The Shear Rate (S.R.) has been calculated assuming the characteristics of newtonian products.

13.2 Adapter for Low Viscosity Materials

13.2.1 Measuring range

| | |
|-------------------|-----------------------|
| MODEL V1L: | 0,3* - 2.000 mPas/cP |
| MODEL V1R: | 3,2* - 21.333 mPas/cP |
| MODEL V1H: | 0,25* - 1.700 dPas/P |
| MODEL V2L: | 0,3* - 6.000 mPas/cP |
| MODEL V2R: | 3.2* - 64.000 mPas/cP |
| MODEL V2H: | 0,25* - 5.120 dPas/P |

- * High rotational speeds required for very low viscosity measurements might have a negative influence on viscosity readings.
- * Viscosity measurements have to be done under laminar flow conditions and not under turbulent ones. Turbulence creates a falsely high viscosity reading.

13.2.2 Description

The Adapter for low viscosity materials is an accessory which consists in a precision spindle rotating inside a sample container. Container fits into a circulating water jacket for precise temperature control.

It needs to be ordered separately and includes the LCP special spindle.

Used together with the **Myr** Viscometers it allows accurate and reproducible measurements on low viscosity materials and also shear rate determinations. It is used to enlarge low viscosity ranges.

This accessory offers 3 versions:

(LCP-001): Standard Adapter

(LCP-001/T): Adapter with embedded temperature sensor in lower cap for a direct readout of sample temperature.

(LCP-001/H): Adapter for high temperature. Thermostating of sample is carried out by immersion of sample container in a temperature bath. Lower and upper caps of sample container are made of Teflon, a material which can support up to 200°C.

13.2.3 Assembly:

- Remove the nut and washer ① from cogged rack ②.
- Fix the rod extension ③ between stand and cogged rack ② through nut and washer ①. Extension rod is necessary because of the length of the LCP Adapter. Without it, it would be difficult to correctly attach the Adapter to the viscometer.
- Fix the circulating water jacket ④ to the rear support ⑤ through the screw ⑥.
- Close the sample container ⑦ with the lower cap ⑧. Make sure it is properly tightened up.
- Fill up the sample container ⑦. Take care that no air bubbles remain in the bottom of the container. To fill it up, use a large syringe while inclining the container. Quantity of sample required is very small (18 ml).
- Check sample quantity. A correct sample level should cover the spindle completely.
- Hang the LCP spindle ⑨ onto the spindle hook ⑩. Attach spindle hook to the screw ⑪.
- Introduce spindle with hook ⑩ and screw it ⑪ into sample container.
- Insert the sample container ⑦ into the circulating water jacket ④ from below.
- Lock the sample container ⑦ to the circulating water jacket ④. Groove in lower cap ⑫ has to meet fixing screw in circulating water jacket ⑬. Turn sample container to fix it.
- Add on the upper cap ⑭. Take care that spindle does not slip into sample container. Let spindle lean on upper cap.
- Fix the rear support ⑤ to the viscometer through screw ⑮.

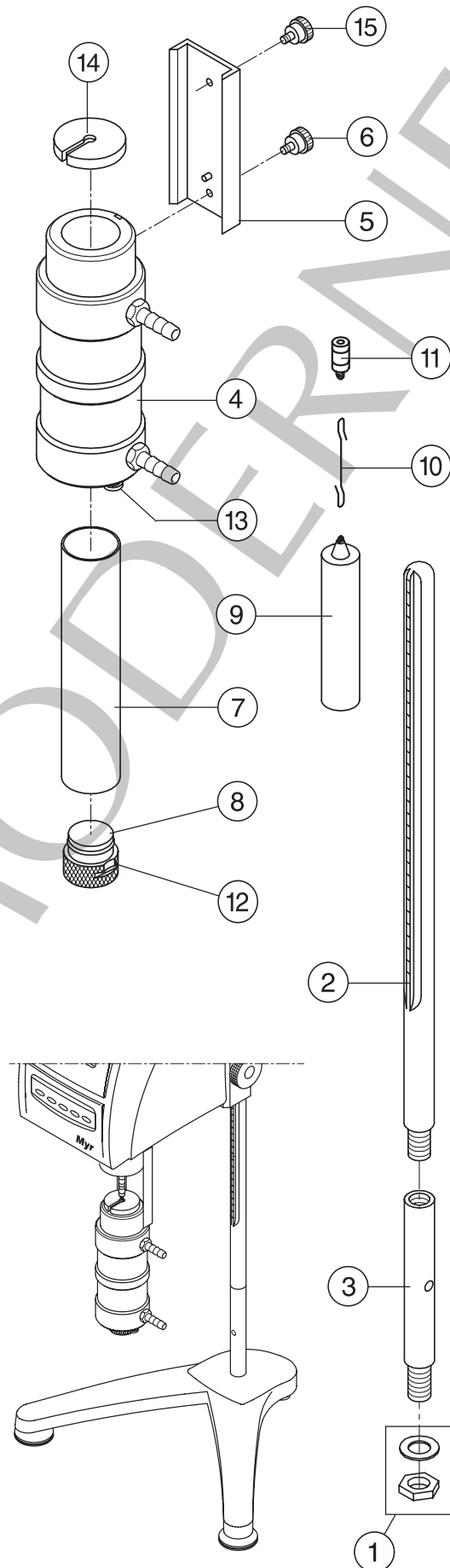

13.2.4 Selection Table for V1 / V2 (L / R / H)

| | V1-L / V2-L | V1-R / V2-R | V1-H / V2-H |
|---------------|-------------------|-------------|----------------------|
| Spindle | LCP | LCP | LCP |
| rpm | Viscosity in mPas | | Viscos. in dPas |
| 0,1 (V2 only) | 6000,00 | 64000,00 | 5,12.10 ³ |
| 0,2 (V2 only) | 3000,00 | 32000,00 | 2,56.10 ³ |
| 0,3 | 2000,00 | 21333,00 | 1,70.10 ³ |
| 0,5 | 1200,00 | 12800,00 | 1,02.10 ³ |
| 0,6 | 1000,00 | 10666,00 | 8,53.10 ² |
| 1 | 600,00 | 6400,00 | 5,12.10 ² |
| 1,5 | 400,00 | 4266,00 | 3,41.10 ² |
| 2 | 300,00 | 3200,00 | 2,56.10 ² |
| 2,5 | 240,00 | 2560,00 | 2,04.10 ² |
| 3 | 200,00 | 2133,00 | 1,7.10 ² |
| 4 | 150,00 | 1600,00 | 1,28.10 ² |
| 5 | 120,00 | 1280,00 | 1,02.10 ² |
| 6 | 100,00 | 1066,00 | 85,0 |
| 10 | 60,00 | 640,00 | 51,0 |
| 12 | 50,00 | 533,00 | 42,0 |
| 20 | 30,00 | 320,00 | 25,0 |
| 30 | 20,00 | 213,00 | 17,0 |
| 50 | 12,00 | 128,00 | 10,0 |
| 60 | 10,00 | 106,00 | 8,53 |
| 100 | 6,00 | 64,00 | 5,12 |
| 200 | 3,00 | 32,00 | 2,56 |
| Increment | 0,01 mPas | 0,16 mPas | |

Special Spindles Characteristics

| Spindle | Shear Rate (S.R.) (Seg. ⁻¹) | Sample Volume (cc) |
|---------|--|-----------------------|
| LCP | 1,224 · rpm | 18 |

The Shear Rate (S.R.) has been calculated assuming the characteristics of newtonian products.

13.3 Adapter for Helicoidal movement

13.3.1 Measuring range

| | |
|-------------------|------------------------------|
| MODEL V1L: | 156* - 9.400.000 mPas/cP |
| MODEL V1R: | 1.660* - 100.000.000 mPas/cP |
| MODEL V1H: | 133* - 2.666.660 dPas/P |
| MODEL V2L: | 156* - 6.000 mPas/cP |
| MODEL V2R: | 1.660* - 64.000 mPas/cP |
| MODEL V2H: | 133* - 8.000.000 dPas/P |

- * High rotational speeds required for very low viscosity measurements might have a negative influence on viscosity readings.
- * Viscosity measurements have to be done under laminar flow conditions and not under turbulent ones. Turbulence creates a falsely high viscosity reading.

13.3.2 Description

Used together with the **Myr** Viscometers, the Adapter for Helicoidal movement allows comparative viscosity measurements in substances which cannot be analyzed using standard methods and spindles. This accessory should be used to measure viscosity in creams, gels, gelatines, materials which do not flow easily.

The Adapter for helicoidal movement is an accessory which consists in a motorized unit which makes the measuring head move up and down between the 2 stopper rings. When touching one of the stoppers unit changes direction of motion automatically. This movement permits spindle to trace a helicoidal path in material avoiding holes and channels in material.

Adapter is supplied with 6 T-type special spindles (PA,PB,PC,PD,PE,PF)

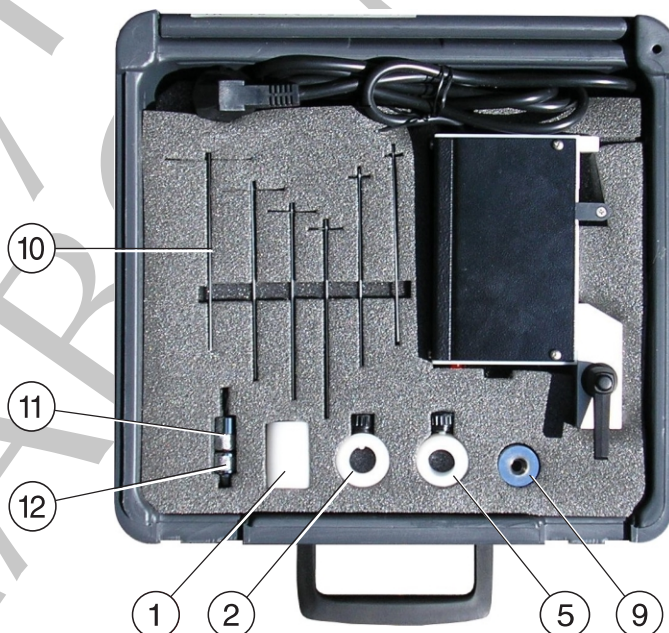

13.3.3 Assembly:

- Remove the nut and washer from cogged rack ⑦.
- Fix cogged rack ⑦ in stand through nut and washer. The toothed side of the cogged rack must face the rear part of the stand.
- Introduce the security socket ① through cogged rack.
- Introduce the lower stopper ring ② through cogged rack and fix it with the screw. Take care not to tighten the screw very much.
- Insert the adapter for helicoidal movement into the cogged rack and fix it by releasing displacement button ③.
- Screw on the upper stopper ring ⑤ and fix it through the screw. Take care not to tighten the screw very much.
- Level the unit

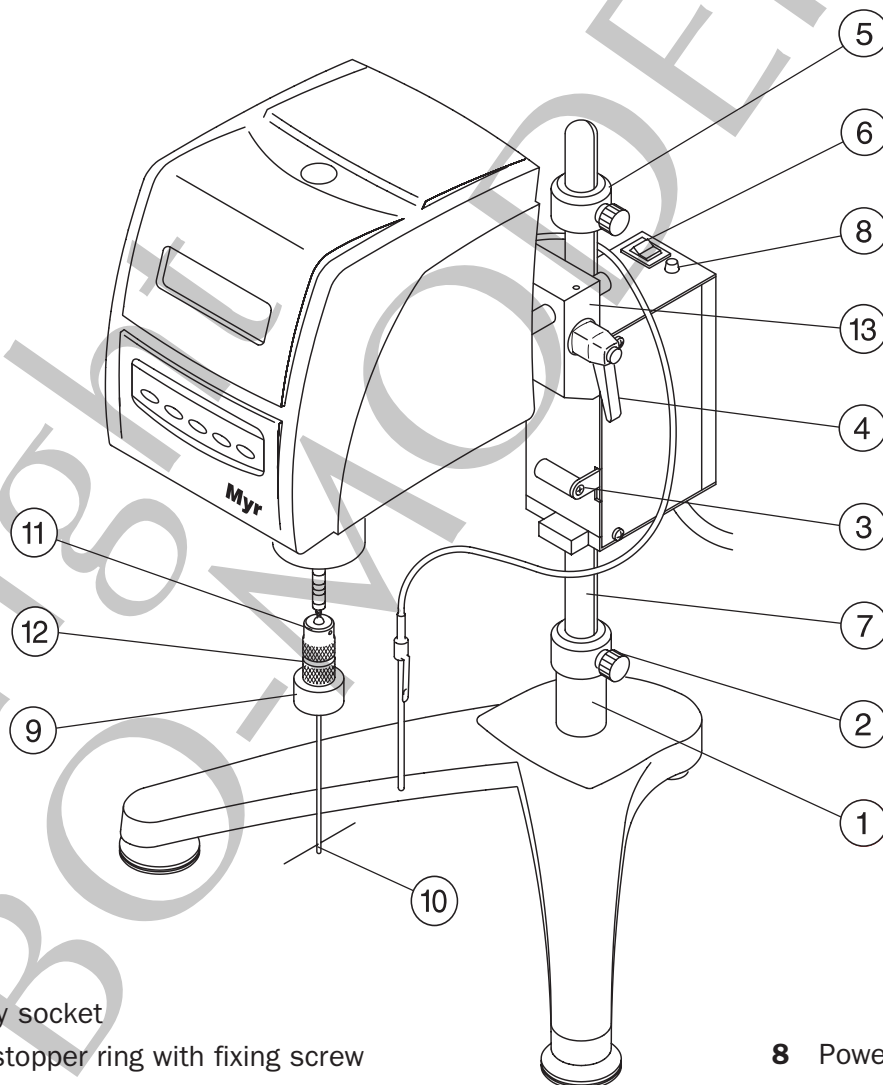

- | | |
|---|-----------------------------|
| 1 Security socket | 8 Power indicator |
| 2 Lower stopper ring with fixing screw | 9 Counterweight |
| 3 Displacement button for helicoidal adapter | 10 Set of T spindles |
| 4 Fixing lever for viscometer measuring head | 11 Coupling screw |
| 5 Upper stopper ring with fixing screw | 12 Counter nut |
| 6 ON/OFF switch | 13 Clamp |
| 7 Cogged rack | |

- Attach the viscometer to the adapter through clamp ⑬ and tighten it through lever ④.
- Screw counterweight ⑨ to counter nut + coupling screw ⑫, ⑪.
- Loosen slightly union between counter nut and coupling screw. Do not separate both parts.
- Introduce required T-spindle ⑩ in counter weight ⑨ and tighten it up. There should always remain a gap between counter nut and coupling screw.
- Attach coupling screw ⑪ to viscometer screwing it clockwise. Both, coupling screw and thread in shaft have to be clean.
- Place sample container under viscometer and introduce spindle in sample by pressing the displacement button ③.
- Fix correctly stopper rings considering the following limits:
Upper stopper: the spindle remains in sample
Lower stopper: Spindle must not touch the bottom of the sample container. This might seriously damage spindle shaft and can lead to errors in viscosity reading.
- Connect viscometer and Adapter to the mains. Switch viscometer on and select spindle and speed.
- Switch ON Adapter ⑥. Check that power indicator lights up ⑧.

13.3.4 Selection Table for V1-L / V2-L

| Spindle | PA | PB | PC | PD | PE | PF |
|---------------|--------------------|---------------------|--------------------|--------------------|--------------------|--------------------|
| rpm | Viscosity in mPas | | | | | |
| 0,1 (V2 only) | $1,9 \cdot 10^5$ | $3,79 \cdot 10^5$ | $4,0 \cdot 10^5$ | $1,9 \cdot 10^6$ | $4,7 \cdot 10^6$ | $9,4 \cdot 10^6$ |
| 0,2 (V2 only) | $9,4 \cdot 10^4$ | $1,9 \cdot 10^5$ | $4,7 \cdot 10^5$ | $5,4 \cdot 10^5$ | $2,2 \cdot 10^6$ | $4,7 \cdot 10^6$ |
| 0,3 | $62,4 \cdot 10^3$ | $124,8 \cdot 10^3$ | $312 \cdot 10^3$ | $624 \cdot 10^3$ | $1,56 \cdot 10^6$ | $3,12 \cdot 10^6$ |
| 0,5 | $37,44 \cdot 10^3$ | $74,88 \cdot 10^3$ | $187,2 \cdot 10^3$ | $374,4 \cdot 10^3$ | $936 \cdot 10^3$ | $1,872 \cdot 10^6$ |
| 0,6 | $31,2 \cdot 10^3$ | $62,4 \cdot 10^3$ | $156 \cdot 10^3$ | $312 \cdot 10^3$ | $780 \cdot 10^3$ | $1 \cdot 10^6$ |
| 1 | $18,72 \cdot 10^3$ | $37,44 \cdot 10^3$ | $93,6 \cdot 10^3$ | $187,2 \cdot 10^3$ | $468 \cdot 10^3$ | $936 \cdot 10^3$ |
| 1,5 | $12,48 \cdot 10^3$ | $24,96 \cdot 10^3$ | $62,4 \cdot 10^3$ | $124,8 \cdot 10^3$ | $312 \cdot 10^3$ | $624 \cdot 10^3$ |
| 2 | $9,36 \cdot 10^3$ | $18,72 \cdot 10^3$ | $46,8 \cdot 10^3$ | $93,6 \cdot 10^3$ | $234 \cdot 10^3$ | $468 \cdot 10^3$ |
| 2,5 | $7,488 \cdot 10^3$ | $14,976 \cdot 10^3$ | $37,44 \cdot 10^3$ | $74,88 \cdot 10^3$ | $187,2 \cdot 10^3$ | $374,4 \cdot 10^3$ |
| 3 | $6,24 \cdot 10^3$ | $12,48 \cdot 10^3$ | $31,2 \cdot 10^3$ | $62,4 \cdot 10^3$ | $156 \cdot 10^3$ | $312 \cdot 10^3$ |
| 4 | $4,68 \cdot 10^3$ | $9,36 \cdot 10^3$ | $23,4 \cdot 10^3$ | $46,8 \cdot 10^3$ | $117 \cdot 10^3$ | $234 \cdot 10^3$ |
| 5 | $3,744 \cdot 10^3$ | $7,488 \cdot 10^3$ | $18,72 \cdot 10^3$ | $37,44 \cdot 10^3$ | $93,6 \cdot 10^3$ | $187,2 \cdot 10^3$ |
| 6 | $3,12 \cdot 10^3$ | $6,24 \cdot 10^3$ | $15,6 \cdot 10^3$ | $31,2 \cdot 10^3$ | $78 \cdot 10^3$ | $156 \cdot 10^3$ |
| 10 | $1,872 \cdot 10^3$ | $3,744 \cdot 10^3$ | $9,36 \cdot 10^3$ | $18,72 \cdot 10^3$ | $46,8 \cdot 10^3$ | $93,6 \cdot 10^3$ |
| 12 | $1,56 \cdot 10^3$ | $3,12 \cdot 10^3$ | $7,8 \cdot 10^3$ | $15,6 \cdot 10^3$ | $39 \cdot 10^3$ | $78 \cdot 10^3$ |
| Increment | 1 mPas | 1 mPas | 2 mPas | 4 mPas | 8 mPas | 16 mPas |

13.3.5 Selection Table for V1-R / V2-R

| Spindle | PA | PB | PC | PD | PE | PF |
|---------------|--------------------|--------------------|--------------------|--------------------|--------------------|--------------------|
| rpm | Viscosity in mPas | | | | | |
| 0,1 (V2 only) | $2 \cdot 10^6$ | $4 \cdot 10^6$ | $1 \cdot 10^7$ | $2 \cdot 10^7$ | $5 \cdot 10^7$ | $1 \cdot 10^8$ |
| 0,2 (V2 only) | $1 \cdot 10^6$ | $2 \cdot 10^6$ | $5 \cdot 10^6$ | $1 \cdot 10^7$ | $2,5 \cdot 10^7$ | $5 \cdot 10^7$ |
| 0,3 | $666,6 \cdot 10^3$ | $1,3 \cdot 10^6$ | $3,3 \cdot 10^6$ | $6,6 \cdot 10^6$ | $16,6 \cdot 10^6$ | $33,3 \cdot 10^6$ |
| 0,5 | $4 \cdot 10^5$ | $8 \cdot 10^5$ | $2 \cdot 10^6$ | $4 \cdot 10^6$ | $10 \cdot 10^6$ | $20 \cdot 10^6$ |
| 0,6 | $333,3 \cdot 10^3$ | $666,6 \cdot 10^3$ | $1,6 \cdot 10^6$ | $3,3 \cdot 10^6$ | $8,3 \cdot 10^6$ | $16,6 \cdot 10^6$ |
| 1 | $2 \cdot 10^5$ | $4 \cdot 10^5$ | $1 \cdot 10^6$ | $2 \cdot 10^6$ | $5 \cdot 10^6$ | $10 \cdot 10^6$ |
| 1,5 | $133,3 \cdot 10^3$ | $266,6 \cdot 10^3$ | $666,6 \cdot 10^3$ | $1,3 \cdot 10^6$ | $3,3 \cdot 10^6$ | $6,6 \cdot 10^6$ |
| 2 | $1 \cdot 10^5$ | $2 \cdot 10^5$ | $5 \cdot 10^5$ | $1 \cdot 10^6$ | $2,5 \cdot 10^6$ | $5 \cdot 10^6$ |
| 2,5 | $8 \cdot 10^4$ | $16 \cdot 10^4$ | $4 \cdot 10^5$ | $8 \cdot 10^5$ | $2 \cdot 10^6$ | $4 \cdot 10^6$ |
| 3 | $66,6 \cdot 10^3$ | $133,3 \cdot 10^3$ | $333,3 \cdot 10^3$ | $666,6 \cdot 10^3$ | $1,6 \cdot 10^6$ | $3,3 \cdot 10^6$ |
| 4 | $5 \cdot 10^4$ | $1 \cdot 10^5$ | $25 \cdot 10^4$ | $5 \cdot 10^5$ | $1,25 \cdot 10^6$ | $2,5 \cdot 10^6$ |
| 5 | $4 \cdot 10^4$ | $8 \cdot 10^4$ | $2 \cdot 10^5$ | $4 \cdot 10^5$ | $1 \cdot 10^6$ | $2 \cdot 10^6$ |
| 6 | $33,3 \cdot 10^3$ | $66,6 \cdot 10^3$ | $166,6 \cdot 10^3$ | $333,3 \cdot 10^3$ | $833,3 \cdot 10^3$ | $1,6 \cdot 10^6$ |
| 10 | $2 \cdot 10^4$ | $4 \cdot 10^4$ | $1 \cdot 10^5$ | $2 \cdot 10^5$ | $5 \cdot 10^5$ | $1 \cdot 10^6$ |
| 12 | $16,6 \cdot 10^3$ | $33,3 \cdot 10^3$ | $83,3 \cdot 10^3$ | $166,6 \cdot 10^3$ | $416,6 \cdot 10^3$ | $833,2 \cdot 10^3$ |
| Increment | 5 mPas | 10 mPas | 25 mPas | 50 mPas | 125 mPas | 250 mPas |

13.3.6 Selection Table for V1-H / V2-H

| Spindle | PA | PB | PC | PD | PE | PF |
|---------------|-------------------|-------------------|-------------------|-------------------|-------------------|-------------------|
| rpm | Viscosity in mPas | | | | | |
| 0.1 (V2 only) | $1,6 \cdot 10^5$ | $3,2 \cdot 10^5$ | $8,0 \cdot 10^5$ | $1,6 \cdot 10^6$ | $4,0 \cdot 10^6$ | $8,0 \cdot 10^6$ |
| 0.2 (V2 only) | $8,0 \cdot 10^4$ | $1,6 \cdot 10^5$ | $4,0 \cdot 10^5$ | $8,0 \cdot 10^5$ | $2,0 \cdot 10^6$ | $4,0 \cdot 10^6$ |
| 0.3 | $5,33 \cdot 10^4$ | $1,06 \cdot 10^5$ | $2,66 \cdot 10^5$ | $5,33 \cdot 10^5$ | $1,33 \cdot 10^6$ | $2,66 \cdot 10^6$ |
| 0.5 | $3,2 \cdot 10^4$ | $6,4 \cdot 10^4$ | $1,6 \cdot 10^5$ | $3,2 \cdot 10^5$ | $8,0 \cdot 10^5$ | $1,6 \cdot 10^6$ |
| 0.6 | $2,66 \cdot 10^4$ | $5,3 \cdot 10^4$ | $1,33 \cdot 10^5$ | $2,66 \cdot 10^5$ | $6,66 \cdot 10^5$ | $1,33 \cdot 10^6$ |
| 1 | $1,6 \cdot 10^4$ | $3,2 \cdot 10^4$ | $8,0 \cdot 10^4$ | $1,6 \cdot 10^5$ | $4,0 \cdot 10^5$ | $8,0 \cdot 10^5$ |
| 1.5 | $1,06 \cdot 10^4$ | $2,1 \cdot 10^4$ | $5,33 \cdot 10^4$ | $1,06 \cdot 10^5$ | $2,66 \cdot 10^5$ | $5,33 \cdot 10^5$ |
| 2 | $8,0 \cdot 10^3$ | $1,6 \cdot 10^4$ | $4,0 \cdot 10^4$ | $8,0 \cdot 10^4$ | $2,0 \cdot 10^5$ | $4,0 \cdot 10^5$ |
| 2.5 | $6,4 \cdot 10^3$ | $1,28 \cdot 10^4$ | $3,2 \cdot 10^4$ | $6,4 \cdot 10^4$ | $1,6 \cdot 10^5$ | $3,2 \cdot 10^5$ |
| 3 | $5,33 \cdot 10^3$ | $1,06 \cdot 10^4$ | $2,66 \cdot 10^4$ | $5,33 \cdot 10^4$ | $1,33 \cdot 10^5$ | $2,66 \cdot 10^5$ |
| 4 | $4,0 \cdot 10^3$ | $8,0 \cdot 10^3$ | $2,0 \cdot 10^4$ | $4,0 \cdot 10^4$ | $1,0 \cdot 10^5$ | $2,0 \cdot 10^5$ |
| 5 | $3,2 \cdot 10^3$ | $6,4 \cdot 10^3$ | $1,6 \cdot 10^4$ | $3,2 \cdot 10^4$ | $8,0 \cdot 10^4$ | $1,6 \cdot 10^5$ |
| 6 | $2,66 \cdot 10^3$ | $5,33 \cdot 10^3$ | $1,33 \cdot 10^4$ | $2,66 \cdot 10^4$ | $6,66 \cdot 10^4$ | $1,33 \cdot 10^5$ |
| 10 | $1,6 \cdot 10^3$ | $3,2 \cdot 10^3$ | $8,0 \cdot 10^3$ | $1,6 \cdot 10^4$ | $4,0 \cdot 10^4$ | $8,0 \cdot 10^4$ |
| 12 | $1,33 \cdot 10^3$ | $2,66 \cdot 10^3$ | $6,6 \cdot 10^3$ | $1,33 \cdot 10^4$ | $3,33 \cdot 10^4$ | $6,66 \cdot 10^4$ |

12. Calibration

Consult your distributor or specialized technical staff.

13. Troubleshooting

| | |
|---|--|
| The instrument does not operate | Check: <ul style="list-style-type: none">▪ the connection to the mains▪ the rear switch position |
| The spindle does not rotate concentricly | Check: <ul style="list-style-type: none">▪ that the the spindle is correctly adjusted to the shaft▪ that the union between spindle and shaft is clean |
| The instrument does not read zero in vaccum | Check: <ul style="list-style-type: none">▪ that the instrument is leveled correctly |
| Viscosity reading is not stable or little accurate | Check: <ul style="list-style-type: none">▪ that the instrument is leveled correctly▪ that the selection rpm/spindle is correct▪ that the temperature of the sample is stable▪ special characteristics of sample fluid |

LABO-MODERNE

37 rue Dombasle - 75015 Paris

Tél. : 01 45 32 62 54

Fax : 01 45 32 01 09

S.A.V. : 01 42 50 21 95

www.labomoderne.com

info@labomoderne.com